

**PREMIER** 33S Series, High Efficiency 60:80:100:125:160kVA UPS

General information:

<b>POWER (kVA)</b>		<b>60</b>	<b>80</b>	<b>100</b>	<b>125</b>	<b>160</b>
UPS typology		ON LINE – Double Conversion ECO MODE – Stand by				
Nominal output power (Cos Ø 0.8)	(kVA)	60	80	100	125	160
Nominal output power (Cos Ø 1.0)	(kW)	48	64	80	100	128
Efficiency AC ÷ AC	(%)	>93				
Eco-Mode		>98				
Heat dissipation at nominal load and voltage	kW	3.8	4.8	6.0	7.5	9.6
	kcal /hour(x1000)	3.3	4.2	5.2	6.5	8.3
UPS ambient temperature	(°C)	0 ~ +40				
BATTERY ambient temperature	(°C)	0 ~ +25				
UPS storage temperature	(°C)	-10 ~ +70				
BATTERY storage temperature	(°C)	-10 ~ +60				
Relative humidity (non condensing)	(%)	<95				
Altitude	(m)	<1000 (Above See Level)				
Power de-rating for altitude > 1000m		According to "IEC62040-3", max 2000m With 1% derating for +100m				
Ventilation		FORCED				
Requested cooling air volume	(km <sup>3</sup> /h)	1.6	1.8	2.1	2.3	2.5
Audible noise level (according EN 50091)	(dB)	<60				
Protection degree		IP 20				
Standard battery type lead acid	(N° cells)	300				
Electromagnetic compatibility EMI		According to "EN62040-2" (CE Label)				
Paint		RAL 9001				
Dimensions	(mm)	W = 815, D = 825, H = 1670				
Accessibility		Front and top access for service				
Weights (without battery)	(kg)	570	600	630	662	720
Static load (without battery)	(kg/m <sup>2</sup> )	948	998	1048	1101	1198
Input/output cable connection		Bottom Side (Top Side on Request)				
Transport		Base provided for forklift handling				
Transport mechanical stress		According to "IEC62040-3"				
Design standard		According to "IEC EN62040 "ISO9000:2000" - "ISO 14001"				
Free contact interface		Optional				
Serial communication interface		RS232 - USB, RS485(Option)				
Parallel configuration		Up to 5+1 redundant				

Block diagram:

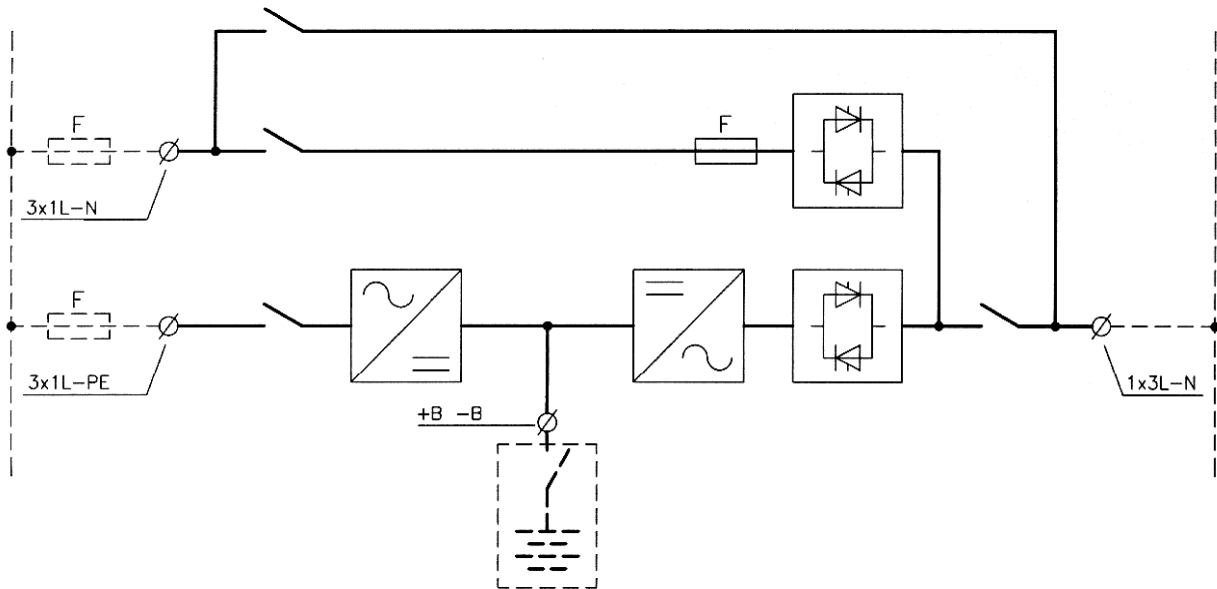

Description

- The UPS is designed following the criteria of low environmental impact.
- The quantity of the raw material used on the magnetic components and the number of semiconductors is minimised by advanced design criteria.
- The high overall efficiency and input power factor reduces the operating costs during the normal operation of the UPS.
- The inverter transformer prevents direct feed-through of the battery potential into the critical load and provides a very high rejection ratio of the power supply disturbances (spikes, surges etc.).
- The UPS is equipped with built-in advanced self-diagnostic program indicating any problems and suggesting to the service engineers how to repair the faults.
- The high input power factor and the low harmonic level of the input current (THDi <3%) minimises dimensioning of the installation in terms of cable size and input circuit breakers. Additionally, these features prevent the need for over sizing generator sets installed upstream.
- Eco-mode. In this intelligent mode, the mains line is continuously monitored and supplies the load with high reliability. If the line is downgraded, and required to be conditioned, the inverter takes care of the load in <4mS.

### UPS Input: Rectifier and Battery charger:

POWER (kVA)		60	80	100	125	160
Nominal Input Voltage (Vac)		3 Phase 400 (+ 10% -20%)				
Input Frequency (Hz)		50 ~ 60 +/- 5				
Input Power Factor		>0.99				
Input Current THD (%)		<3%				
DC Output Voltage Accuracy (%)		+/- 1				
DC Output Voltage Ripple (% rms)		1				
Walk-in time duration (s)		10				
Battery Recharging Characteristic		IU (DIN 41773)				
Temperature Voltage Compensation		Optional				
Maximum Recharging Current @ nominal load (A)		15	15	15	20	20
DCM function can increase up to (max) (A)		50	50	100	100	100
AC-DC converter type		IGBT PFC				
Input protection		Fuses				
Nominal Current Absorbed from Mains (@ nominal load and Battery charged) (A)		75	100	125	156	200
Maximum Current Absorbed from Mains (@ nom. load and max. recharging current) (A)		94	126	157	196	252

### Description

- The input rectifier is designed to minimize the harmonics injected back into the input mains.
- The technology is based on a 6-IGBT matrix PFC, fully digitally controlled by a latest generation 32 bit microcontroller.
- Large input mains variations are allowed, without affecting the battery charge condition.
- The battery charge function is built into the same converter.
- The converter is designed to recharge the battery for extended autonomies.

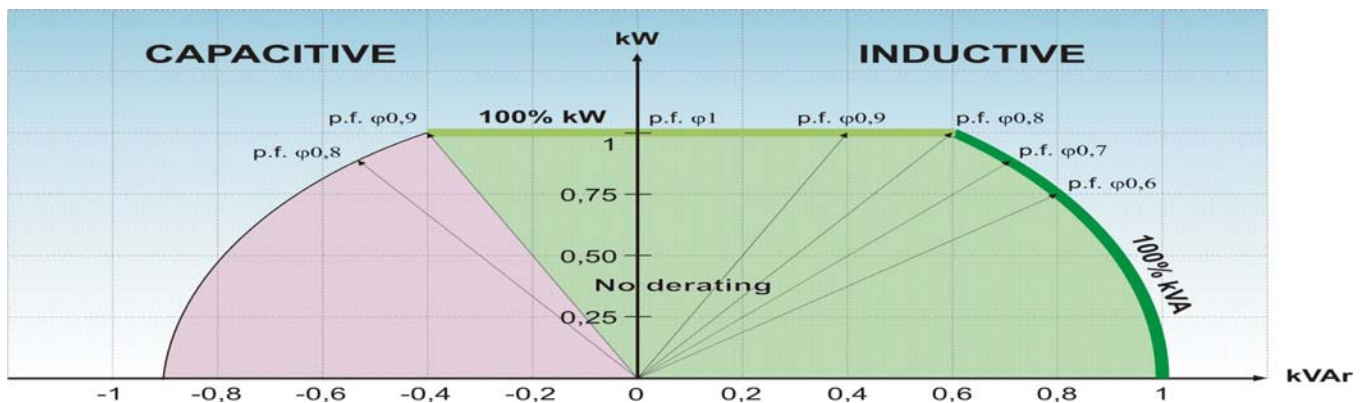

UPS Output: Inverter:

<b>POWER (kVA)</b>	<b>60</b>	<b>80</b>	<b>100</b>	<b>125</b>	<b>160</b>
Inverter Bridge	IGBT (High Frequency Comm.)				
Nominal Output Power (Cos Ø 0.8) (kVA)	60	80	100	125	160
Nominal Output Power (Cos Ø 1.0) (kW)	48	64	80	100	128
Permissible range of load power factor	See Above				
Nominal Output Voltage (Selectable, 3 phase + N) (Vac)	380 - 400 - 415				
Output Voltage Stability (%)					
- Static (Balanced Load)	+/- 1				
- Static (Unbalanced load)	+/- 2				
- Dynamic (Step Load 0~100%~0)	+/- 5				
- Output Volt. Recovery Time (after step load)	<20 ms				
- IEC 62040-3	Class 1				
Phase Angle (°)					
- Balanced Load	+/- 1				
- 100% Unbalanced Load	+/- 1				
Output Frequency (Hz)	50 – 60				
Output Frequency Stability					
- Free Running Quartz Oscillator (Hz)	+/- 0.001				
- Inverter Sync. with Mains (Hz)	+/- 2 (other on request)				
- Slew rate (Hz/s)	1				
Nominal Output Current					
- Cos Ø 0.8 (A)	80	116	145	180	232
- Cos Ø 1.0 (A)	70	93	115	145	186
Overload Capability (%)					
	10 Min	>100....125%			
	1 Min	>125....150%			
	10 s	>150....199%			
	100 ms	at 200%			
Short Circuit Current (A)	140	186	230	290	290
Short Circuit Characteristic	Elect. short circuit protection, current limited at 2 times nominal current (1.5 times for 160kVA). Automatic stop after 5 seconds				
Selectivity	Within ½ cycle (Fuse gl 20% In)				
Output Waveform	Sinusoidal				
Output Harmonic Distortion					
- Linear Load (%)	<1				
- Non Linear Load (Crest factor 3:1) (%)	<5				
- IEC 62040-3	Fully compliant				
Crest Factor (Non-linear load)	3:1				
Efficiency (DC-AC) (%)	>95				

## Description

- The Inverter design is based on a full bridge 6-IGBT matrix, high frequency PWM, fully digitally controlled.
- The output voltage stability and the dynamic response are optimised.
- The selectivity in case of short-circuit is very high and the recovery of the voltage is digitally controlled (Soft Short Recovery Loop "SSRL").

## UPS Output: By-pass:

Automatic Static By-pass		Electronic Thyristor Switch
Protection		Fuses
Nominal Voltage	(Vac)	380 – 400 – 415, 3P+N
Range	(%)	+/-10
Nominal Frequency	(Hz)	50 – 60
Range	(%)	+/- (1 to 5) configurable
Transfer mode		Without break
Transfer: Inverter to automatic by-pass		In case of : -Static switch test -Inverter test -Inverter not operating -Battery end of discharge
Retransfer: Automatic by-pass to Inverter		- Automatic - Block on bypass after 6 switches within 2 minutes, reset by front panel
Overload Capability	(%)	-150 continuously -1000 for 1 cycle
Manual by-pass for maintenance		Standard: - Electronically controlled - No break

## Description

- The manual by-pass is included as standard. The electronic control avoids the risks of power interruption during transfer from inverter to manual by-pass and vice-versa.

Parallel:

Automatic parallel configuration for redundancy/capacity	Up to 5+1 redundant parallel Up to 6 power parallel by an additional card
Basic parallel configuration	Redundant N+1
Connection Type	CAN Bus Loop
Share Accuracy (max unbalance) (%)	10
Maximum Distance between Two Units (m)	10 (more on request)
Overload Capability	N x 200% for 100ms N x 125% for 10 minutes
Automatic By-Pass	On each unit
Manual By-Pass	On each unit (common as option)

Description

- The parallel UPS configuration is provided with control for operation both redundant and capacity increase.
- The parallel control is fully digitally controlled and acts on both active and reactive power on each output phase, allowing an accurate load current sharing among the UPS's, even during transient conditions.
- Parallel control is distributed (not centralised control, but on each UPS microcontroller) and communication among units uses CAN BUS connection loop, providing a highly reliable system without "single points of failure".
- Extremely simple parallel control and interconnections ease the installation and in field upgrading, adding new units to the system according to the customers needs.

## UPS Monitoring:

### LOCAL ON FRONT PANEL

- Synoptic diagram showing: power flow, circuit breaker status and alarms
- LCD display with menu and sub-menu
- Keyboard

### PC (Windows OS)

- Connection point-point UPS-PC via RS232
- Remote connection through modem
- All the local indications, alarms and measures
- Basic troubleshooting
- History events

### RELAY CARD (Optional)

- **SRC card free relay contact**
- Eight signals Alarms/Status are available for remote connections
- Free relay contact

Relay	Description	Alarms/Status
RL1	Common alarm	A30
RL2	Mains failure	A01
RL3	Battery end of discharge	A09
RL4	Inverter not OK	A13
RL5	Bypass feeding load	A16
RL6	Rectifier OK	S01
RL7	Inverter feeding load	S04
RL8	Bypass OK	S06

### REMOTE

- **SNMP adaptor (Optional)**
  - LAN/WAN, web server features and monitoring by browser.
  - UPS operation monitoring and server management.
- **RS485 interface board (Optional)**
  - ModBus protocol
  - UPS operation monitoring



## **OPTIONS**

1. BATTERY TEMPERATURE VOLTAGE COMPENSATION
2. INSULATION TRANSFORMER ON BY-PASS
3. VOLTAGE ADAPTATION AUTO-TRANSFORMERS
4. FREE CONTACTS RELAY CARD
5. SERIAL INTERFACE RS-485 (MOD-BUS protocol)
6. SNMP ADAPTOR
7. MODEM
8. PARALLEL CARD INTERFACE
9. EXTERNAL BATTERY CABINET
10. WALL MOUNTED FUSED SWITCH BOX
11. IN/OUT TOP CABLE ENTRY
12. SPECIAL PAINT

- ◇ Online double conversion technology, <4ms eco-mode
- ◇ 32-bit DSP implementing full digital control
- ◇ Digitally controlled IGBT Bridge, minimises the harmonics reinjected into the mains reducing the harmonic distortion of the current to less than 3%
- ◇ Power factor correction technology resulting in a power factor of greater than 0.99
- ◇ The high efficiency and input power factor reduces the current consumption and operational costs, reducing cable and circuit breaker cost
- ◇ Upstream generator oversizing is not required
- ◇ Dynamic charging mode reduces battery re-charge time
- ◇ Integrated advanced self-diagnostic program
- ◇ Step-by-step procedures described on the LCD display for ease of use
- ◇ Results of electrical measurement, alarm, work condition, event log and battery state are displayed real time on the LCD front panel
- ◇ Mimic flow display to show the operating status of the UPS
- ◇ Battery test included as standard
- ◇ Parallel redundant configurations of up to six units



Unit 8, Riverside Park  
Farnham, Surrey GU9 7UG  
Tel: 01252 714100  
Fax: 01252 733910  
[www.cbsgroupuk.com](http://www.cbsgroupuk.com)  
[sales@cbsgroupuk.com](mailto:sales@cbsgroupuk.com)